

FXR Bracket Support

Brackets

Pre Fabricated Bracket to support cantilever Loads

Material specifications	
Material	Base Plate : S235 JR or equivalent steel U Profile & Mounting Rail : DD11 or equivalent steel
Coatings	Galvanized, Hot-Dip Galvanized (HDG), Powder Coating*, Zinc Magnesium*

Applications

- Bracing for FXR Mounting Rails structures for carrying higher loads
- Supporting installation of medium to heavy-duty ventilation ducts, plumbing & firefighting pipes and cable trays

Features & Benefits

- Easy to install with less components
- Prefabricated for rapid installation
- High load bearing capacity owing to special material properties and design.

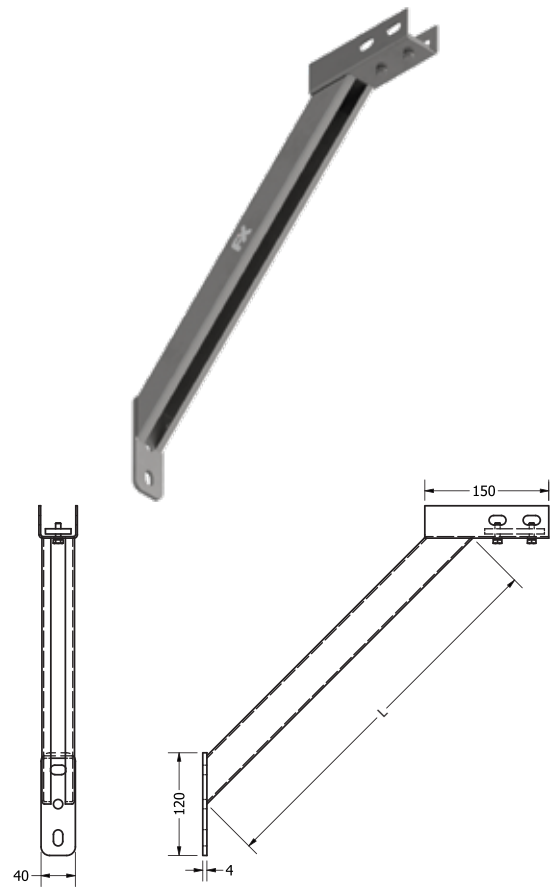

Select Variant

Article No.		Product Description	FXR Mounting Rail	Length (L) (mm)	Max. Recommended Load (N)		Pack Size (Nos)
Galvanized (vz)	HDG (fvz)				Mounted on Channel	Mounted on Wall	
632000	632001	FXR Bracket support, 440 mm	41 21-41 82	440	2500	6000	5
632010	632011	FXR Bracket support, 900 mm	41 21-41 82	900	2000	3000	1

*Available on request