

Connection element for attachment of FXC Mounting Channels to steel girders without welding or drilling

Material specifications	
Material	S235 JR or equivalent steel
Coatings	Galvanized, Hot-Dip Galvanized (HDG), Powder Coating*, Zinc Magnesium*



Applications

- Connection of FXC Mounting Channels to steel girders without welding or drilling

Features & Benefits

- Easy to install, Pre-assembled Kit
- Enables secured transfer of loads from FXC Mounting Channel to steel girders
- Allows adjustment of FXC Mounting Channel along and across the supporting beam
- Suitable for Flange thicknesses of common steel girder profiles

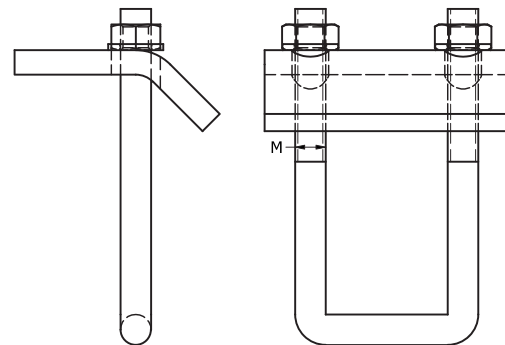

Load Table

For FXC Mounting Rails	M	Max. permitted loading/pair [N] with fasteners		
		M8	M10	M12
38 24, 38 48	M8	1000	2200	5000
38 40	M8	2500	2800	5000
40 60	M8	3500	4000	8300
38 40, 38 80	M10	2500	2800	5000
40 60,40 80,40 120	M10	3500	4000	8300

Select Variant

Article No.		Product Description	M	Pack Size (Nos)
Galvanized (vz)	HDG (fvz)			
368000	368001	FXC Girder Cleat M6 - 27 18, 28 30	M6	50
368010	368011	FXC Girder Cleat M8 - 38 24, 38 40	M8	20
368020	368021	FXC Girder Cleat M8 - 40 60, 38 80, 40 80	M8	20
368030	368031	FXC Girder Cleat M10 - 38 40, 40 60	M10	10
368040	368041	FXC Girder Cleat M10 - 38 80, 40 80	M10	10
368050	368051	FXC Girder Cleat M10 - 40 120	M10	10

*Available on request